

ITEM	QTY.	DESCRIPTION
1	1	CATERPILLAR C27/800 Kw STAND-BY- 725 Kw PRIME GEN SET PACKAGE (GP-0453) & 12 LEAD RE-CONNECTABLE SR4 GENERATOR
2	1	30' ISO CONTAINER w/ 2 - 30' PERSONNEL ACCESS DOORS, 2' THK MINERAL WOOL, 1' THK SOUND FOAM, ALUMINUM PERFORATED LINER AND FULL FLOOR MINERAL WOOL INSULATION
3	1	30' TANDUM ISO CHASSIS w/ AIR RIDE SUSPENSION, AIR BRAKES & ICC LIGHT PACKAGE
4	1	KIM HOTSTART JACKET WATER HEATER DUAL CIRCUIT 6KW
5	1	FLEXIBLE RADIATOR DISCHARGE DUCT
6	1	EXTERIOR LOAD PAN ASSEMBLY w/ PADLOCKABLE DOOR, LOAD BUS ASSEMBLY, REMOTE START/STOP TERMINALS, BATTERY CHARGER/GENERATOR HEATER RECEPTACLE, JACKET WATER HEATER RECEPTABLES & SAFETY LOAD DOOR SHUT DOWN SWITCH AND GROUND STUD
7	2	FIXED LOUVER INTAKE ASSEMBLY w/ SOUND BAFFLE, 1' FOAM LINER & BIRD SCREEN
8	2	CATERPILLAR LOGO DECALS ON ALUMINUM PLATE
9	2	EXHAUST EXTENSIONS w/ INSULATION BLANKET ASSEMBLY
10	1	STABILIZER JACKS WITH STORAGE CLAMPS
11	1	12' HOSPITALAL GRADE INSULATED EXHAUST SILENCER
12	1	S.S 8" EXHAUST FLEX ASSEMBLY w/ ADAPTER FLANGE & EXHAUST BLANKET
13	1	RADIATOR DISCHARGE DIVERTER ASSEMBLY
14	1	CATCO BATTERY CHARGER w/ SHOCK MOUNTING
15	1	2500Amp CIRCUIT BREAKER w/ 50 TO 100% ADJUSTABLE TRIP MOUNTED IN GENERATOR TERMINATION BOX
16	1	240/480v DUAL VOLTAGE CHANGE OVER BOARD ASSEMBLY
17	1	1000 Gal UL142 FUEL TANK ASSEMBLY w/ SECONDARY CONTAINMENT
18	1	CATERPILLAR 4D BATTERY SET w/ CABLE SET
19	1	EXTERIOR WATER DRAIN w/ INTERIOR VALVE
20	1	EXTERIOR OIL DRAIN w/ INTERIOR VALVE
21	1	ENGINE CRANKCASE FUMES DISPOSAL LINE
22	1	ALUMINUM PERSONNEL ACCESS LADDER ASSEMBLY w/ (2) REMOVABLE HAND RAILS
23	2	CATERPILLAR MUD FLAPS
24	1	ACCESS LADDER STORAGE BOX
25	2	10 Lbs DRY CHEMICAL FIRE EXTINGUISHER w/ MOUNTING BRACKET
26	1	0 TO 60 MINUTE D.C. LIGHT TIMER
27	3	24VDC LIGHT FIXTURE

FUEL FITTING GROUP

- A - ENGINE FUEL SUPPLY LINE w/ ISOLATION VALVE
- B - ENGINE EXCESS FUEL RETURN LINE
- C - MANUAL FUEL FILL w/ PADLOCKABLE CAP
- D - FUEL LEVEL SIGHT GAUGE
- E - WORKING TANK VENT
- F - LOW FUEL LEVEL ALARM SWITCH
- G - EMERGENCY TANK VENT
- H - WORKING RUPTURE BASIN VENT
- I - EMERGENCY RUPTURE BASIN VENT
- J - EXTERIOR TANK DRAIN w/ INTERIOR VALVE

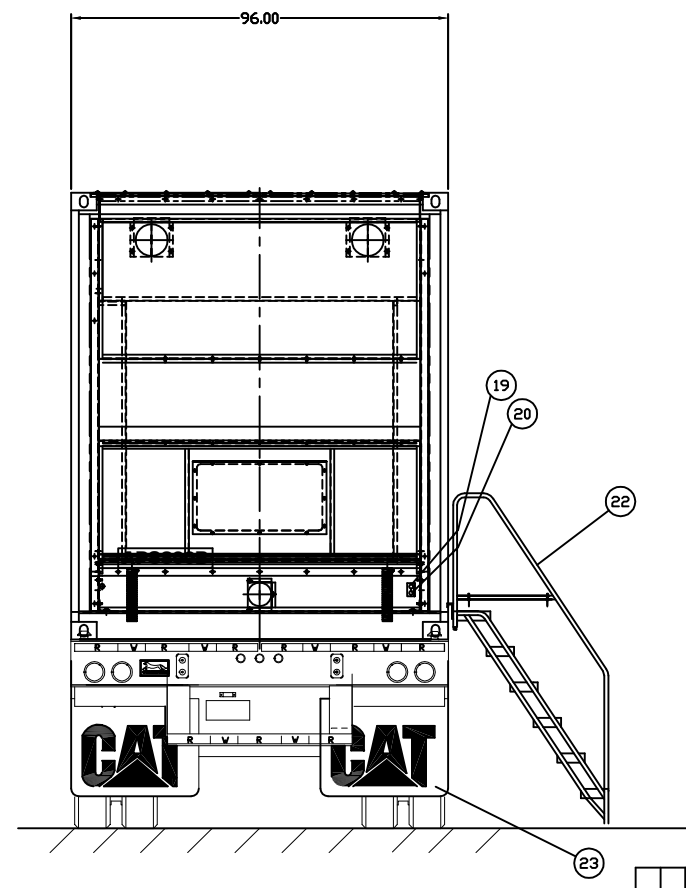
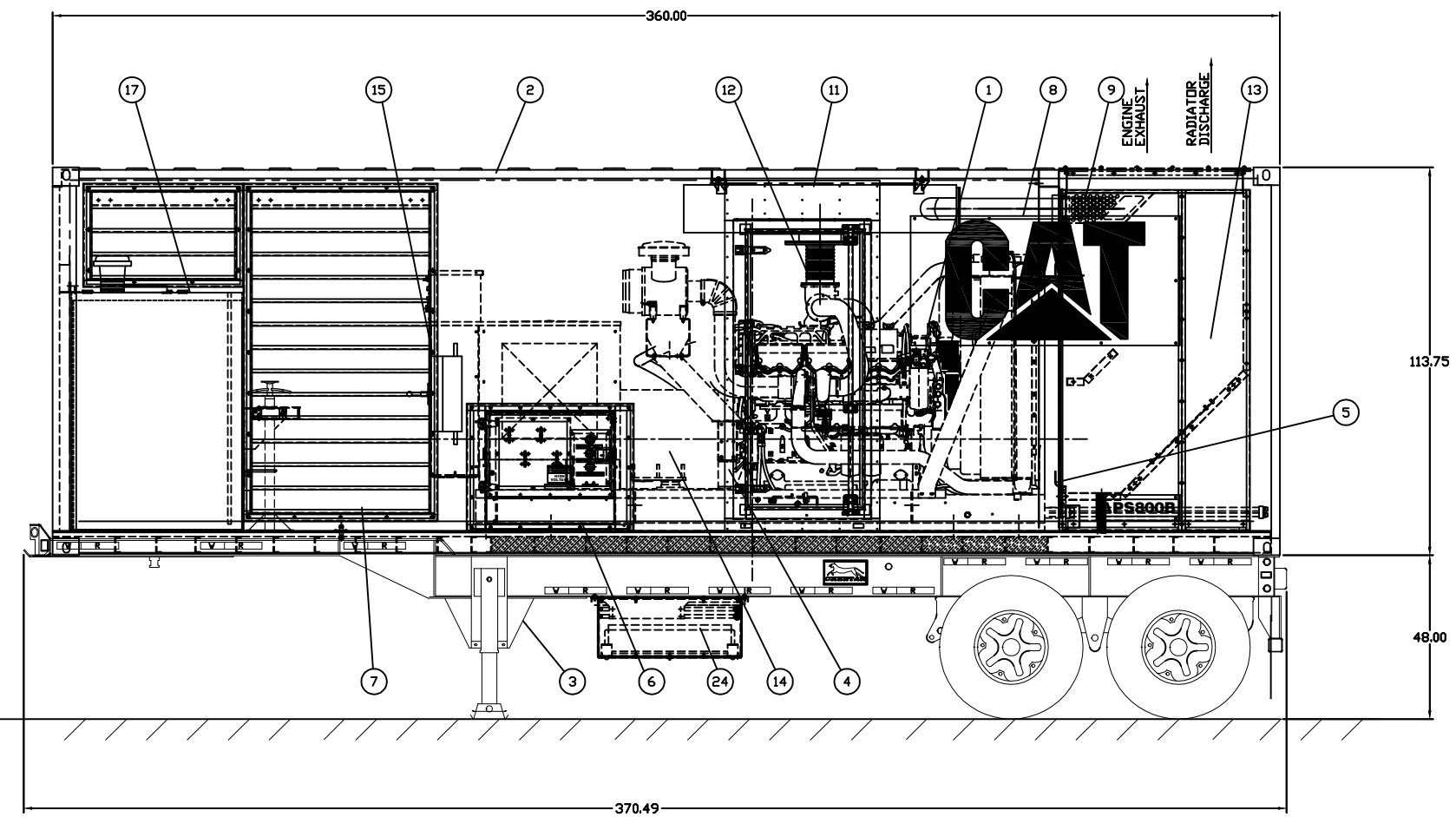

REAR DOORS REMOVED FOR CLARITY

		ALTORFER POWER SYSTEMS 6315 W. FAUBER RD. PHONE (309) 697-1234 BARTONVILLE, IL 61607 FAX (309) 282-7546	
THIS DOCUMENT CONTAINS PROPRIETARY INFORMATION OF ALTORFER, INC. WITHOUT THE WRITTEN PERMISSION OF ALTORFER, INC. ANY COPYING OR OTHER USE EXCEPT THAT FOR WHICH IT WAS INTENDED IS PROHIBITED.		PROJECT REFERENCE APSS00B 30 FT. RENTAL UNIT	
ALL DIMENSIONS IN INCHES UNLESS OTHERWISE SPECIFIED	FILE DF/80A	SCALE/SHEET SIZE 1=25/D	DRAWN BY D. RICHARDSON
TOLERANCES: XX ± 0.100 XXX ± 0.060 XXXX ± 0.005	THIRD ANGLE PROJECTION	SHEET 1 OF 1	QUOTE NUMBER DATE 9/29/08
CHANGE NOTICE DATE BY	TITLE APSS00B - SOUND ATTENUATED CATERPILLAR C27 DUAL VOLTAGE RENTAL CONTAINER	WORK ORDER NUMBER	DRAWING NUMBER 80A825