

INCH 80G142

ITEM	QTY.	PART NO.	DESCRIPTION
1	3	80G108	INFORMATIONAL FILM
2	1	80G122	INFORMATIONAL FILM
3	1	4W-5138	FILM-SYMBOL
4	1	9Y-4275	FILM
5	2	80G128	INFORMATIONAL FILM
6	1	80G129	INFORMATIONAL FILM
7	2	80G143	INFORMATIONAL FILM

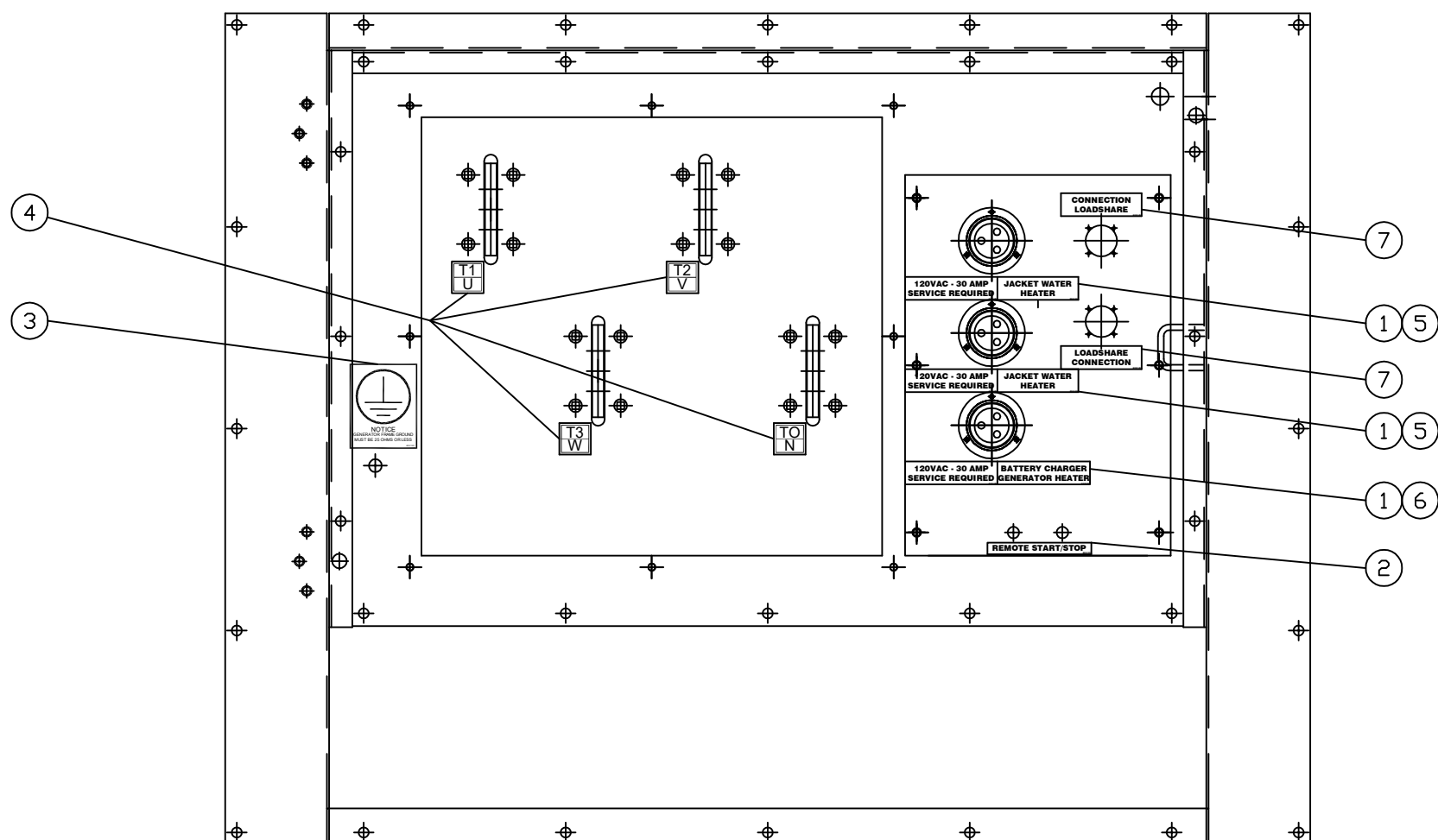

DATE BY		ALTORFER			ALTORFER POWER SYSTEMS			
					6315 W. FAUBER RD. PHONE (309) 697-1234 BARTONVILLE, IL 61607 FAX (309) 282-7546			
THIS DOCUMENT CONTAINS PROPRIETARY INFORMATION OF ALTORFER, INC. WITHOUT THE WRITTEN PERMISSION OF ALTORFER, INC., ANY COPYING OR OTHER USE EXCEPT THAT FOR WHICH IT WAS INTENDED IS PROHIBITED								
CHANGE NOTICE		ALL DIMENSIONS IN INCHES UNLESS OTHERWISE SPECIFIED		FILE	PROJECT REFERENCE			
				DF/80G	C27/C32 POWER MODULE			
		TOLERANCES: X.X ± 0.100 X.XX ± 0.060 X.XXX ± 0.005		THIRD ANGLE PROJECTION	SCALE/SHEET SIZE	DRAWN BY	QUOTE NUMBER	
		ANGULAR ± 1°			1=10/A	D. RICHARDSON		
				SHEET	DATE	WORK ORDER NUMBER		
				1 OF 1	12/6/06			
		TITLE					DRAWING NUMBER	
		LOAD PAN FILM GROUP					80G142	
2	1	ND.	4	3	2	1		

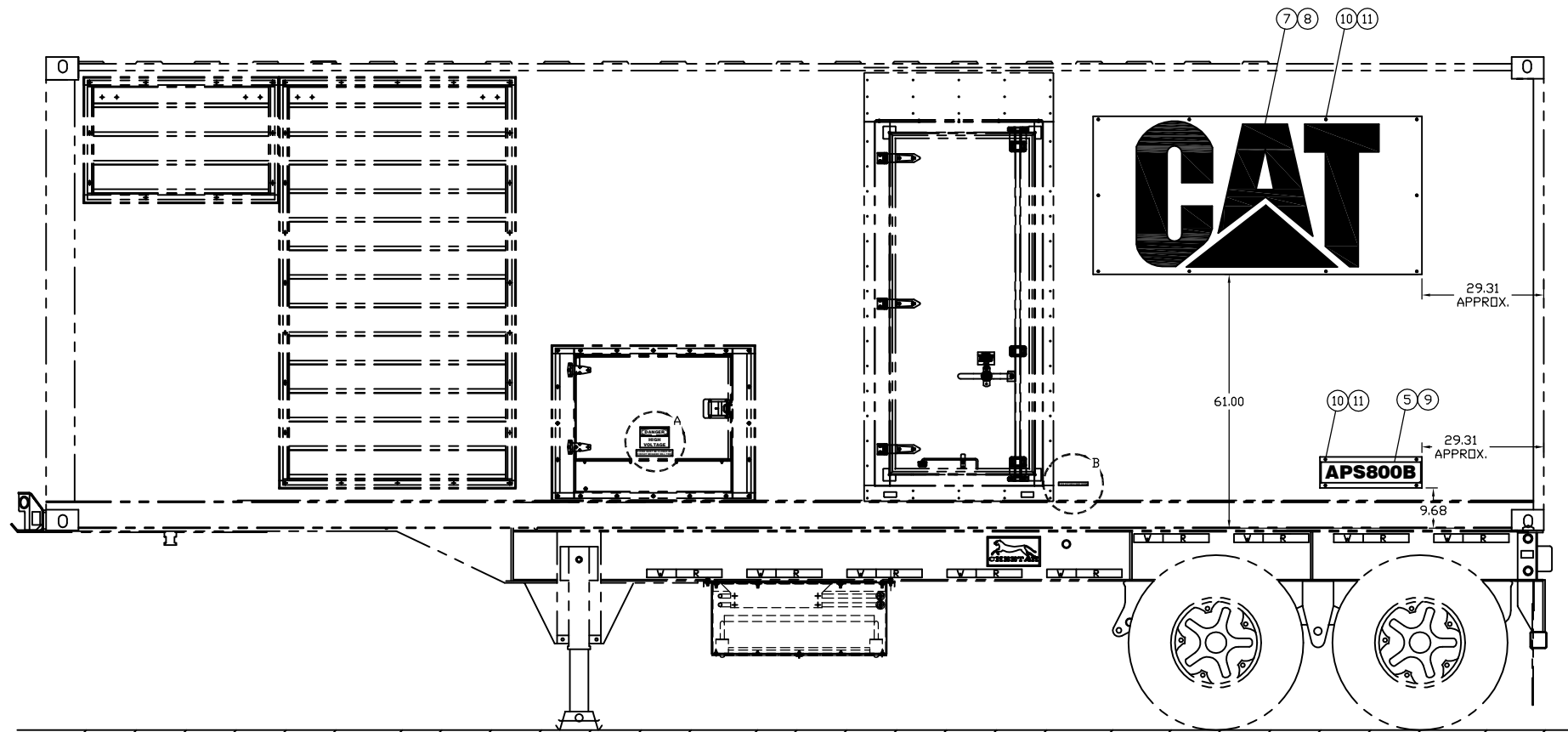

LEFT SIDE VIEW OF CONTAINER

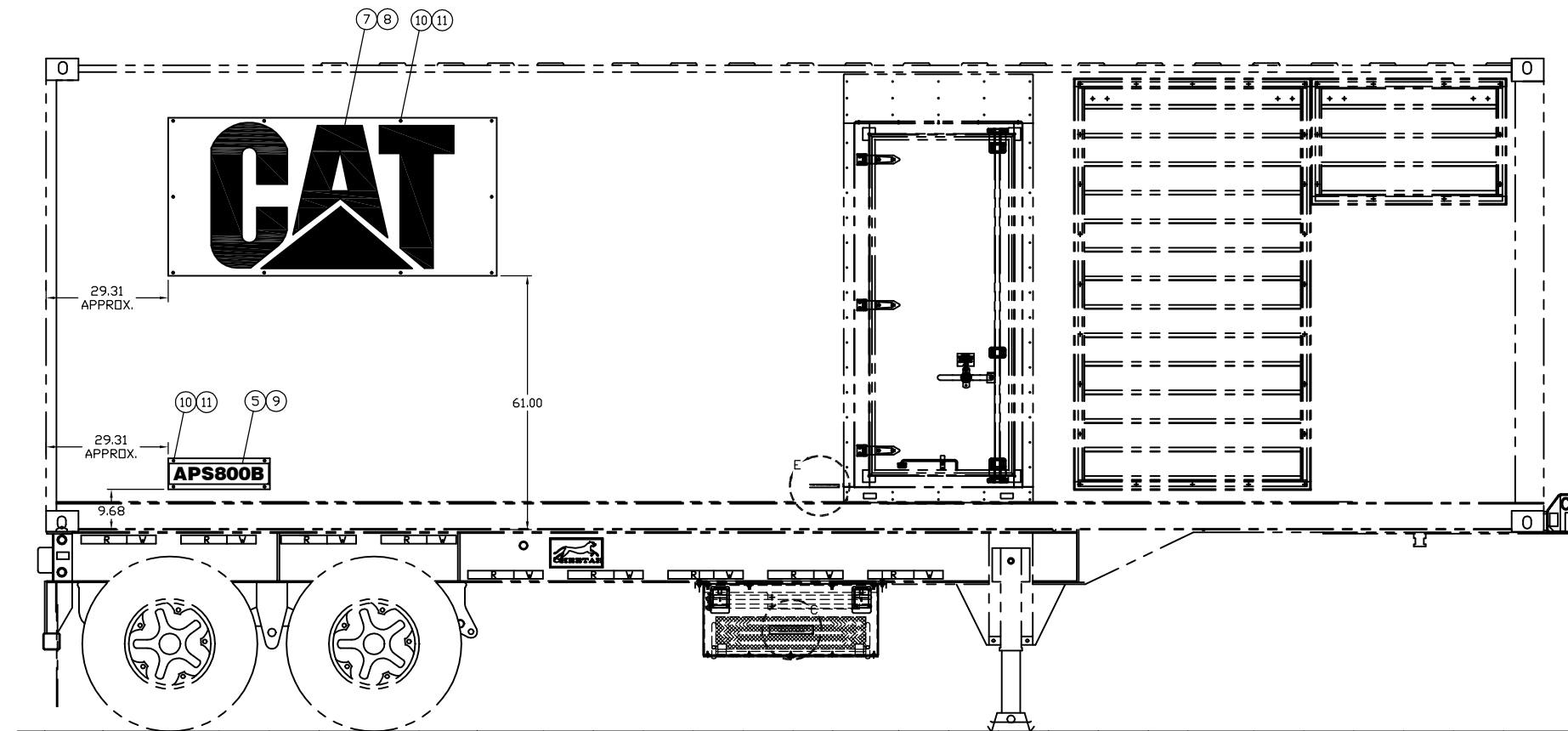

RIGHT SIDE VIEW OF CONTAINER

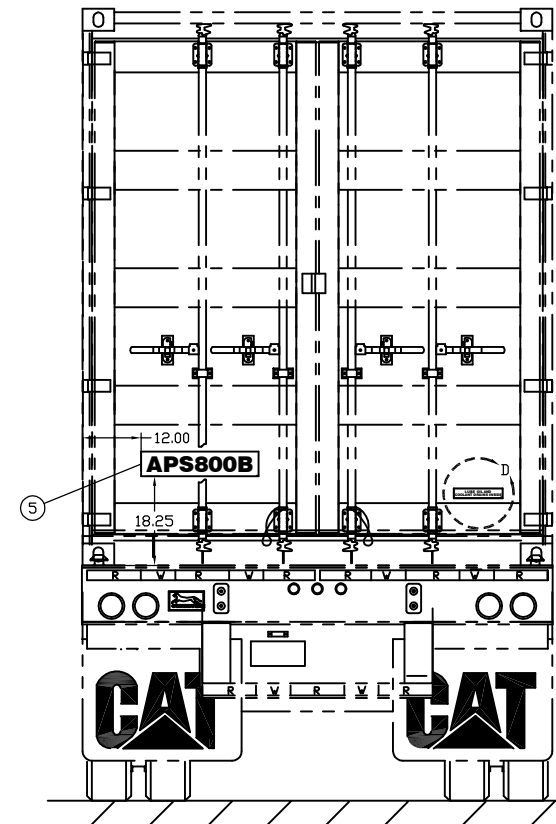

ITEM	QTY.	PART NO.	DESCRIPTION
1	1	81G104	INFORMATIONAL FILM
2	1	80G105	INFORMATIONAL FILM
3	1	80G106	INFORMATIONAL FILM
4	1	80G107	INFORMATIONAL FILM
5	3	80G146	INFORMATIONAL FILM
6	2	80G121	INFORMATIONAL FILM
7	2	7E-7799	FILM-TRADEMARK
8	2	80C192	14 GA. 38.00 X 79.00
9	2	80C193	14 GA. 7.50 X 24.50
10	28	30840	PSQ SMS 14X1 Z A KEG
11	28	N1125257	1/4" NEOPRENE WASHER

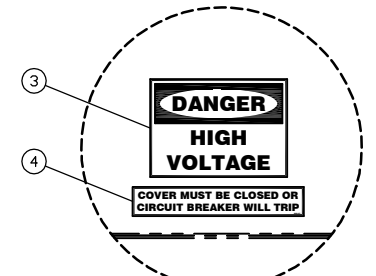

VIEW A
AT E-6
SCALE 4=1

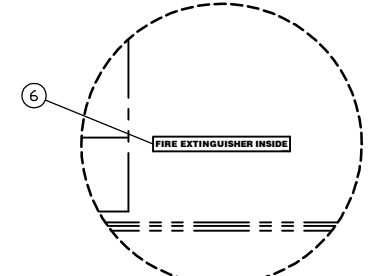

VIEW B
AT E-5
SCALE 4=1

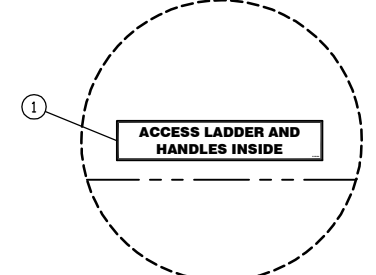

VIEW C
AT E-2
SCALE 4=1

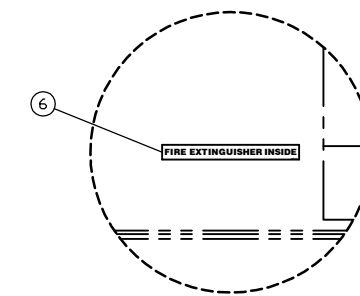

VIEW E
AT B-6
SCALE 4=1

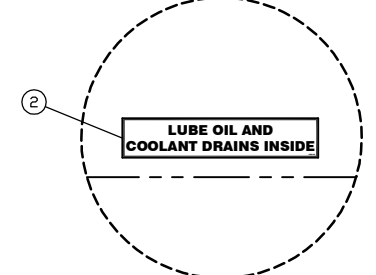

VIEW D
AT E-2
SCALE 4=1

		ALTORFER POWER SYSTEMS 6315 W. FAUBER RD. BARTONVILLE, IL 61607 PHONE (309) 697-1234 FAX (309) 282-7546		
CHANGE NOTICE NO. 1	THIS DOCUMENT CONTAINS PROPRIETARY INFORMATION OF ALTORFER, INC. WITHOUT THE WRITTEN PERMISSION OF ALTORFER, INC., ANY COPYING OR OTHER USE EXCEPT THAT FOR WHICH IT WAS INTENDED IS PROHIBITED.	FILE DF/80G	PROJECT REFERENCE APS800B C27 POWER MODULE	
	ALL DIMENSIONS IN INCHES UNLESS OTHERWISE SPECIFIED	SCALE/SHEET SIZE 1=20/D	DRAWN BY D. RICHARDSON	
	TOLERANCES: XX ± 0.100 ANGLE X.XX ± 0.060 PROJECTION .XXX ± 0.005	SHEET 1 OF 1	DATE 9/30/08	QUOTE NUMBER WORK ORDER NUMBER
	ANGULAR ± 1°	TITLE FILM GROUP EXTERIOR FILM GROUP	DRAWING NUMBER 80G145	

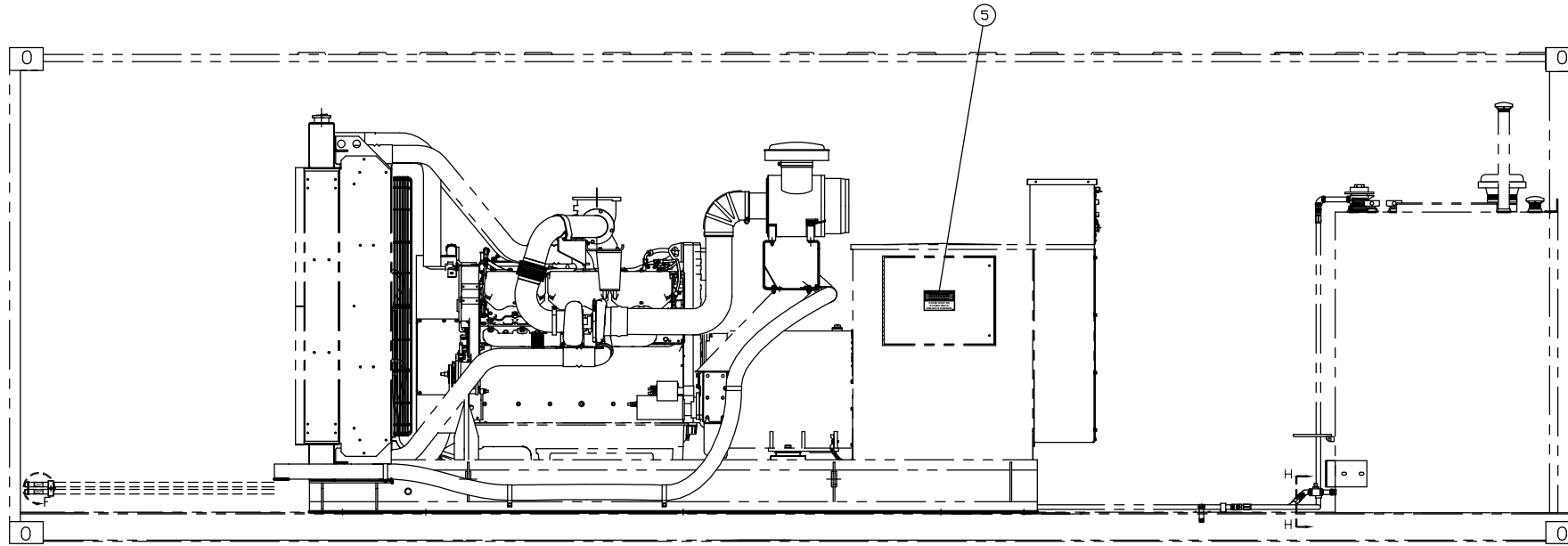

RIGHT SIDE VIEW OF CONTAINER

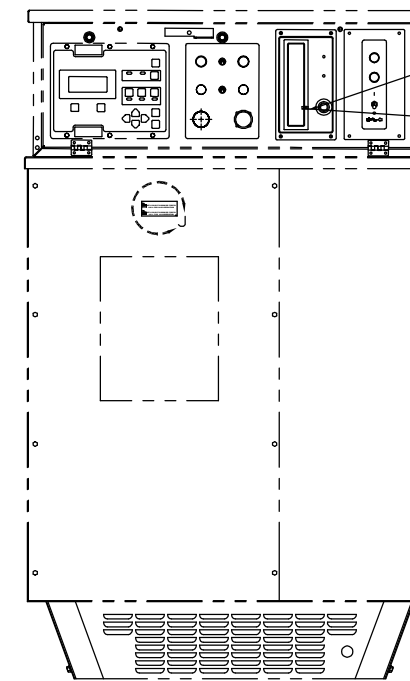

SECTION G-G
AT B-7
SCALE 2=1

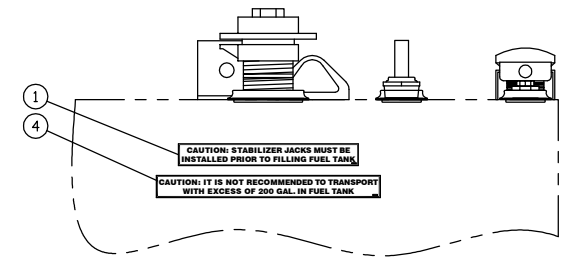

SECTION A-A
AT B-7
SCALE 3=1

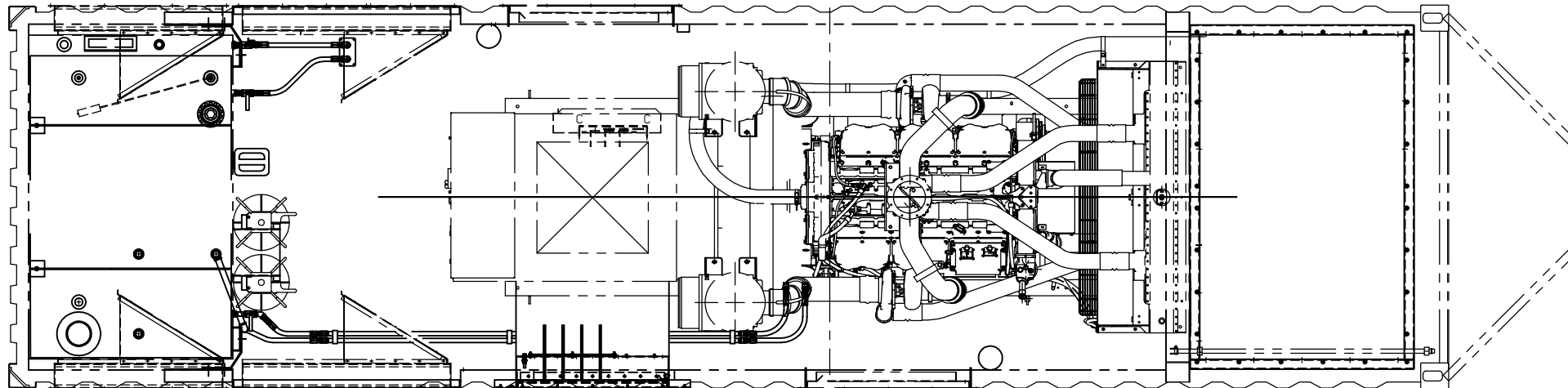

TOP VIEW OF CONTAINER

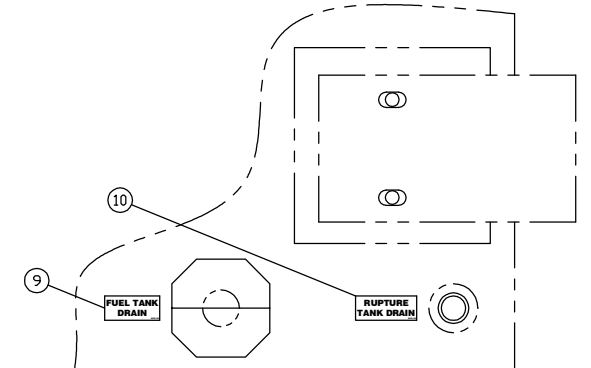

SECTION H-H
AT E-4
SCALE 5=1

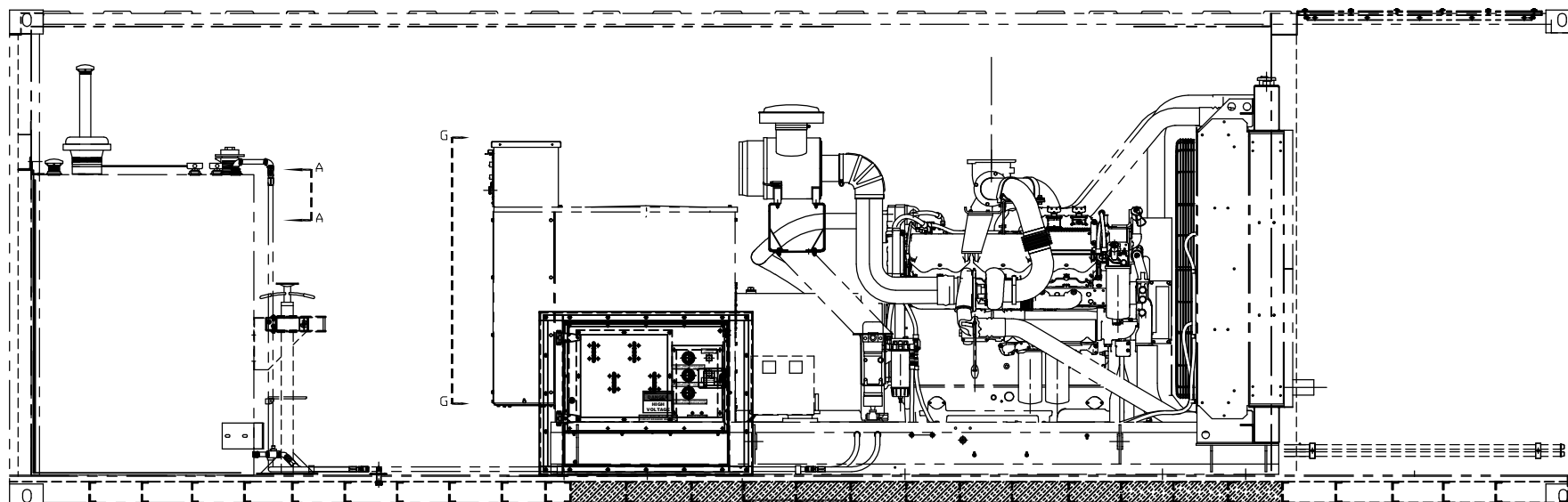

LEFT SIDE VIEW OF CONTAINER

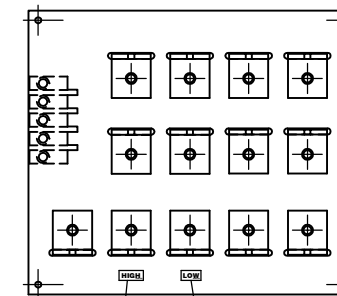

SECTION C-C
AT D-6
SCALE 4=1

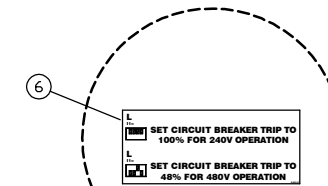

VIEW J
AT E-3
SCALE 5=1

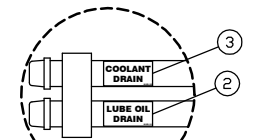

VIEW F
AT A-4
SCALE 5=1

NOTE A: PLACE OVER 'EPS SUPPLYING LOAD'
NOTE B: PLACE OVER 'LOW STARTING AIR PRESSURE'

DATE BY		ALTORFER		ALTORFER POWER SYSTEMS	
		6315 W. FAUBER RD.		PHONE (309) 697-1234	
		BARTONVILLE, IL 61607		FAX (309) 282-7546	
THIS DOCUMENT CONTAINS PROPRIETARY INFORMATION OF ALTORFER, INC. WITHOUT THE WRITTEN PERMISSION OF ALTORFER, INC., ANY COPYING OR OTHER USE EXCEPT THAT FOR WHICH IT WAS INTENDED IS PROHIBITED.		FILE		PROJECT REFERENCE	
ALL DIMENSIONS IN INCHES UNLESS OTHERWISE SPECIFIED		DF/80G		APS800B C27 POWER MODULE	
TOLERANCES: XX ± 0.100 ANGLE XXX ± 0.060 PROJECTION XXX ± 0.005		SCALE/SHEET SIZE 1=20/D		DRAWN BY D. RICHARDSON	
CHANGE NOTICE		SHEET 1 OF 1		DATE 12/10/08	
ANGULAR ± 1°		TITLE		DRAWING NUMBER	
		FILM GROUP INTERIOR FILM GROUP		80G148	

ITEM	QTY.	PART NO.	DESCRIPTION
1	1	80G109	INFORMATIONAL FILM
2	1	80G111	INFORMATIONAL FILM
3	1	80G112	INFORMATIONAL FILM
4	1	80G136	INFORMATIONAL FILM
5	1	80G118	INFORMATIONAL FILM
6	1	80G147	INFORMATIONAL FILM
7	1	80G123	INFORMATIONAL FILM
8	1	80G124	INFORMATIONAL FILM
9	1	80G125	INFORMATIONAL FILM
10	1	80G126	INFORMATIONAL FILM
11	1	80G130	INFORMATIONAL FILM

CAUTION: STABILIZER JACKS MUST BE INSTALLED PRIOR TO FILLING FUEL TANK.
CAUTION: IT IS NOT RECOMMENDED TO TRANSPORT WITH EXCESS OF 200 GAL. IN FUEL TANK.

FUEL TANK DRAIN

RUPTURE TANK DRAIN

COOLANT DRAIN

LUBE OIL DRAIN